

Requirements and procedures to file a request for accelerated examination to CIPO under the PPH program with the State Intellectual Property Office of the People's Republic of China

PPH pilot agreement between CIPO and the State Intellectual Property Office of the People's Republic of China introduction

The Patent Prosecution Highway (PPH) pilot agreement program with the State Intellectual Property Office of the People's Republic of China (CNIPA) which commenced on September 1, 2013 will be extended once again on September 1, 2018 for a period of three years ending on August 31, 2021. The latest extension also introduces the possibility for applicants to file a PCT-PPH request at CIPO, that is, to use CNIPA's international work products.

CIPO and CNIPA will evaluate the results of the pilot agreement to determine whether and how the agreement should be further extended.

CIPO reserves the right to limit or terminate our participation in the CIPO-CNIPA pilot agreement at any stage if the volume of participation exceeds a manageable level, or for any other reason. In the event the CIPO-CNIPA pilot agreement is terminated CIPO will provide written notice not less than three months prior to the date of termination.

These requirements and procedures may be amended at any time with the consent of both offices involved. CIPO and CNIPA may, if they wish, develop office-specific guidelines, e.g. to reflect their respective legal terminology and processes, and can apply additional flexibility beyond these requirements as they see fit.

CIPO will process requests for advanced prosecution under the PPH pilot free of charge. If the PPH pilot becomes a permanent program, CIPO will evaluate what, if any, fees should apply. Regular fees (Schedule II of the Patent Rules) for requesting examination will continue to apply during the PPH pilot.

Procedures for filing a request to CIPO for accelerated examination under the PPH

An applicant should file a request for accelerated examination under the Patent Prosecution Highway (PPH) to CIPO by submitting a completed PPH request [form](#) and providing the documents required for participation in the CIPO-CNIPA PPH as noted below in Annex B.

The PPH request form must be the uppermost document to ensure that the request is correctly processed. The PPH request form is available in the [PPH section](#) for the respective agreement.

The request for accelerated examination under the PPH may be made by mail, fax, or electronically via the Innovation, Science and Economic Development Canada website as per the CIPO patent correspondence procedures.

All subsequent correspondence with the office must be clearly identified as relating to a PPH application to ensure that the correspondence is correctly processed. Please prominently mark each page of the covering letter in subsequent correspondence with the term "PPH".

The PPH request will be considered by an Examiner, and, if all requirements are met, the Examiner will conduct the accelerated examination. Each Canadian patent application will be examined in accordance with the Canadian Patent Act and Patent Rules, and CIPO's Patent Office Practice.

If the Examiner determines that the claims on file do not sufficiently correspond to one or more of those claims indicated as allowable by CNIPA, the applicant will be notified that the request for accelerated examination is not granted. To re-enter the PPH, the applicant must amend the claims accordingly and reapply altogether by submitting a new request form.

At any time during the prosecution of a PPH application, if the Examiner determines that the claims on file do not sufficiently correspond to one or more of those claims indicated as

allowable by CNIPA, the applicant will be notified that the application has been removed from the PPH and examination will proceed in a non-accelerated manner.

All amendments to the claims made with the request for accelerated examination under the PPH will be entered regardless of whether the request is granted or not.

Annex A: Requirements for requesting accelerated examination to CIPO under the PPH program with CNIPA

In order to be eligible to participate in the CIPO-CNIPA PPH the following six requirements must be met:

1. The applications before CIPO and CNIPA have the same earliest date. The same earliest date may be the priority or filing date of: a corresponding national application filed with CNIPA or a corresponding PCT international application for which CNIPA has been ISA and/or IPEA. Illustrated examples of Canadian patent applications that may request accelerated examination under the CIPO-CNIPA PPH are given in Annex F;
2. The corresponding application(s) must have been substantively examined, including consideration of novelty and inventive step and have at least one claim indicated by CNIPA in its capacity as a national Office to be patentable/allowable. The claim(s) determined as novel, inventive and industrially applicable by CNIPA as the ISA and/or IPEA has/have the meaning of patentable/allowable for the purposes of this notice;
3. All claims in the CIPO application for which a request for participation in the PPH pilot is made must sufficiently correspond to the patentable/allowable claims in the CNIPA corresponding application(s). Annex C provides further guidance of the criteria for evaluating whether the claims sufficiently correspond;
4. Substantive examination of the CIPO application for which participation in the PPH is requested has not begun. Substantive examination is considered to have begun when CIPO issues a first office action (i.e.: an examination report or a notice of allowance);
5. The CIPO application is open to public inspection or a request to open the application to public inspection accompanies the PPH request; and,
6. CIPO has received a request for examination or a request for examination and payment of the prescribed fee accompanies the PPH request.

Annex B: Documents Required for Participation in the CIPO-CNIPA PPH

For participation in the CIPO-CNIPA PPH pilot at CIPO the applicant is required to:

1. File a complete request for participation in the PPH.
 - o A complete request includes a fully completed PPH request form (available in the [PPH section](#)). Particularly, a claims correspondence table is required in addition to an identification of all relevant work product(s) as well as the version of the claims found to be allowable where CIPO is requested to retrieve work products and claims from a Dossier Access System;
2. Submit a copy of all the CNIPA work product(s) which are relevant to the allowability of the claims of the corresponding application(s), if not available via Dossier Access Systems (see Annex D for pertinent Dossier Access Systems and Annex E for relevant eligible work products);
3. Submit a copy of the claims found to be allowable by CNIPA, if not available via Dossier Access Systems (see Annex D for pertinent Dossier Access Systems); and,
4. Submit translations of any of the documents listed in points 2. or 3. above if the required work product(s) and/or claims are not available in English or French. If it is impossible for the patent examiner to understand even the outline of the translated office action(s) or the scope of the translated claims, due to inadequate translation, the examiner can request that the applicant resubmit a translation.

Patent documents (where not publicly available) and non-patent literature cited by CNIPA may be provided with the request. While provision of these documents is optional, it may further accelerate examination. Applicants may file translations of citations as part of the supporting documentation when initially requesting accelerated examination under the PPH to allow prompt consideration of the citations, if they so desire. The CIPO Examiner may request translation of citations using the standard CIPO examination procedure where translation of a cited document is necessary.

In addition, applicants should notify CIPO of any office actions from CNIPA that are relevant to patentability which issued after submitting a PPH request, wherein CNIPA has reversed a prior indication of allowability. Further, if the office actions cannot be retrieved by CIPO, they should be submitted with the notification.

CIPO will use Dossier Access Systems and machine translations to access and assess supporting documentation to the maximum extent possible. If CIPO has difficulty in obtaining documents listed in Annex B and translations thereof, the applicant may be asked to submit them. When machine translations are determined by CIPO to be of insufficient quality, then the applicant may also be asked to provide manual translation.

The applicant need not provide further copies of documentation if they have already submitted the documents noted above to CIPO through simultaneous or past procedures related to the application.

Annex C: Principles

Consistent with the "MOTTAINAI" concept, PPH eligibility will be based on work available from CNIPA regardless of where the application was first filed, so long as the applications share the same effective date (priority or filing) and the disclosures support the claimed subject matter.

All claims on file, as originally filed or as amended, for examination under the PPH must sufficiently correspond to one or more of those claims indicated as allowable by CNIPA. Claims are considered to sufficiently correspond where, accounting for differences due to translations and claim format, the claims before CIPO are of the same or similar scope as the claims in the corresponding application(s), or the claims before CIPO are narrower in scope than the claims in the corresponding application(s).

In this regard, a claim that is narrower in scope occurs when a claim in the corresponding application(s), is amended to be further limited by an additional feature that is supported in the specification (description and/or claims).

A claim before CIPO which introduces a new/different category of claims to those claims indicated as allowable by CNIPA is not considered to sufficiently correspond. For example, where the claims in the corresponding application(s), only contain claims to a process of manufacturing a product, then the claims before CIPO are not considered to sufficiently correspond if the claims before CIPO introduce product claims that are dependent on the corresponding process claims.

(In practice, however, a certain degree of flexibility regarding 'sufficiently correspond' may be provided at the discretion of CIPO.)

Annex D: Pertinent Dossier Access Systems

Pertinent Dossier Access Systems	
Office	Dossier Access System
CIPO	Canadian Patents Database
CNIPA	Patent Search and Service System of CNIPA
WIPO	Patentscope
Global Dossier	Via WIPO CASE

Annex E: Eligible Work Products

Corresponding claims are considered to be allowable as indicated in the following work products:

OEE	Document
CNIPA	<p>Eligible CNIPA national work products: Granted Patent Publication and/or in an office action. A CNIPA office action includes a "第一次审查意见通知书 (First Office Action)"¹ and "授予发明专利权通知书 (Notification to Grant Patent Right for Invention)".</p> <p>Eligible CNIPA PCT work products: Written Opinion of the International Searching Authority (WO-ISA) * Written Opinion of the International Preliminary Examination Authority (WO-IPEA) * International Preliminary Report on Patentability (IPRP) *</p> <p>* CNIPA does not need to be the receiving Office for these work products to be eligible.</p>

Annex F: Examples of Canadian patent applications that may request accelerated examination under the CIPO-CNIPA PPH at CIPO

In the examples below Office of Earlier Examination (OEE) refers to CNIPA, also in its capacity as ISA and/or IPEA, the work product of which is used as a basis for the PPH request, while the Office of Later Examination (OLE) refers to CIPO as the office before which participation in the PPH pilot programme is being requested.

Example A

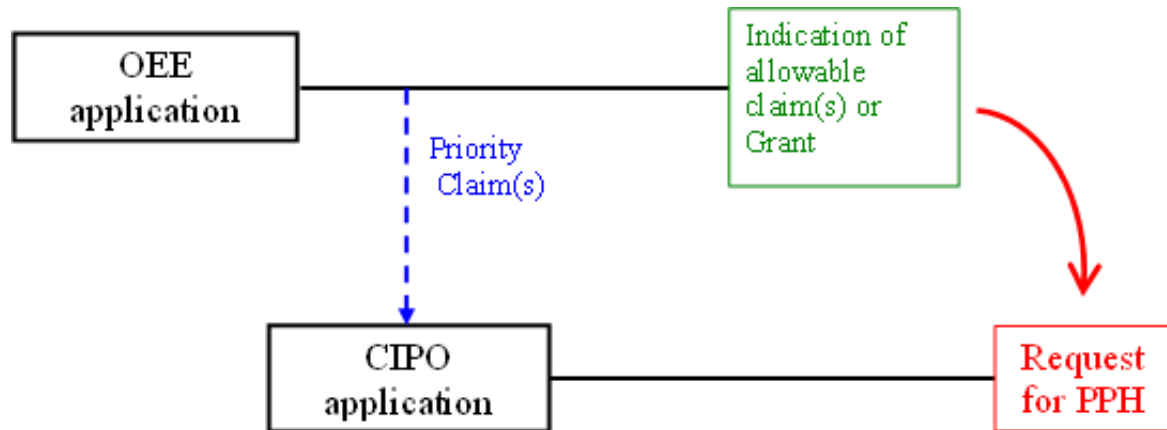

A nationally filed application at CIPO validly claims priority under the Paris Convention from an Office of Earlier Examination (OEE) national application which has an indication of allowable subject matter or has granted as a patent. A PPH request is made for the nationally filed application at CIPO, based on the indication of allowable subject matter in the OEE or the OEE granted patent.

Example B

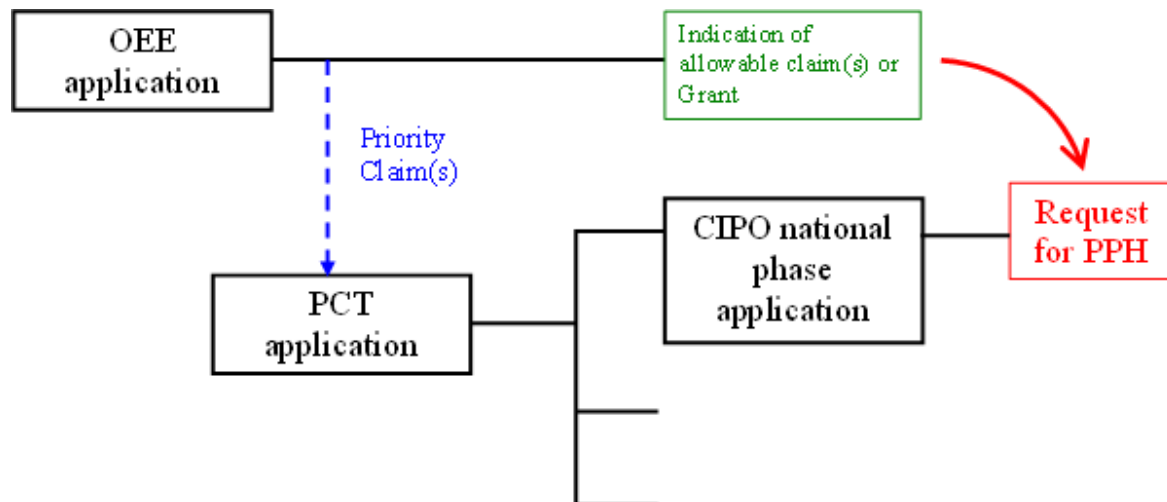

A PCT international application is filed and enters national phase at CIPO. The PCT application validly claims priority from an OEE national application which has an indication of allowable subject matter or has granted as a patent. A PPH request is made for the national phase application at CIPO, based on the indication of allowable subject matter in the OEE or the OEE granted patent.

Example C

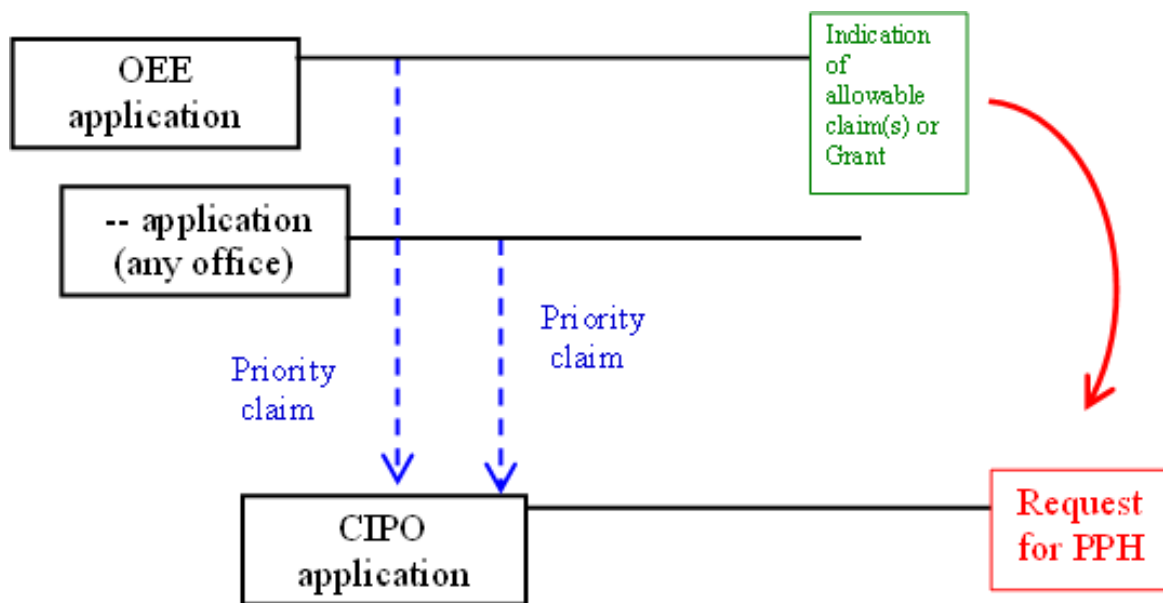

A nationally filed application at CIPO validly claims priority under the Paris Convention from two earlier applications: an OEE national application and a national application filed at any office. The OEE national application has an indication of allowable subject matter or has granted as a patent. A PPH request is made for the nationally filed application at CIPO, based on the indication of allowable subject matter in the OEE or the OEE granted patent.

Example D

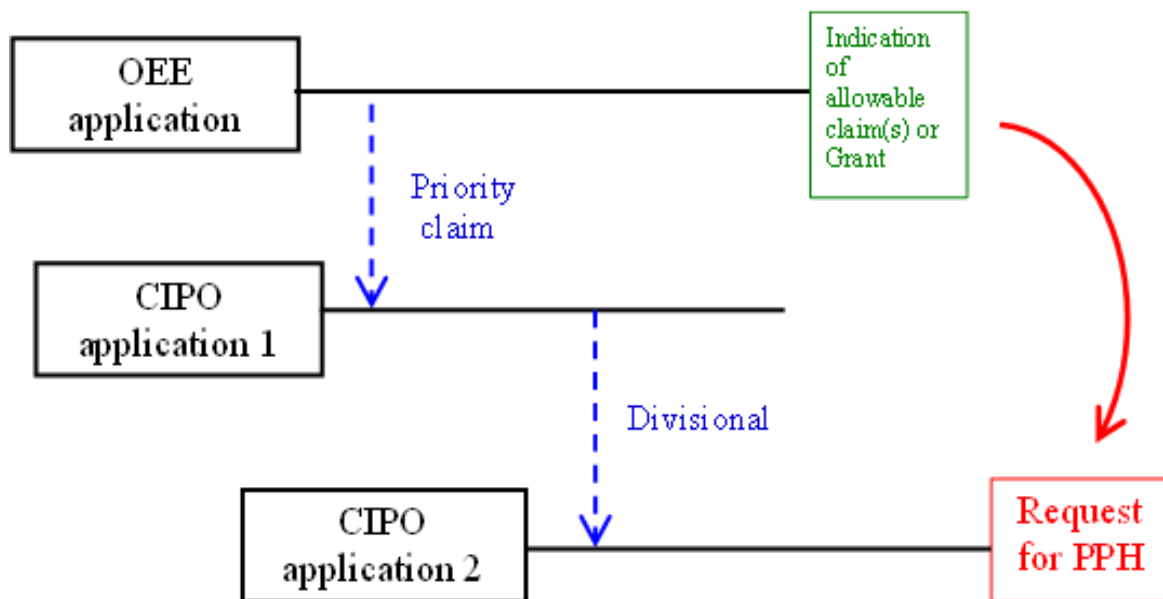

A nationally filed application at CIPO validly claims priority under the Paris Convention from an OEE national application which has an indication of allowable subject matter or has granted as a patent. A PPH request is made for a divisional of the nationally filed application at CIPO, based on the indication of allowable subject matter in the OEE or the OEE granted patent.

Example E

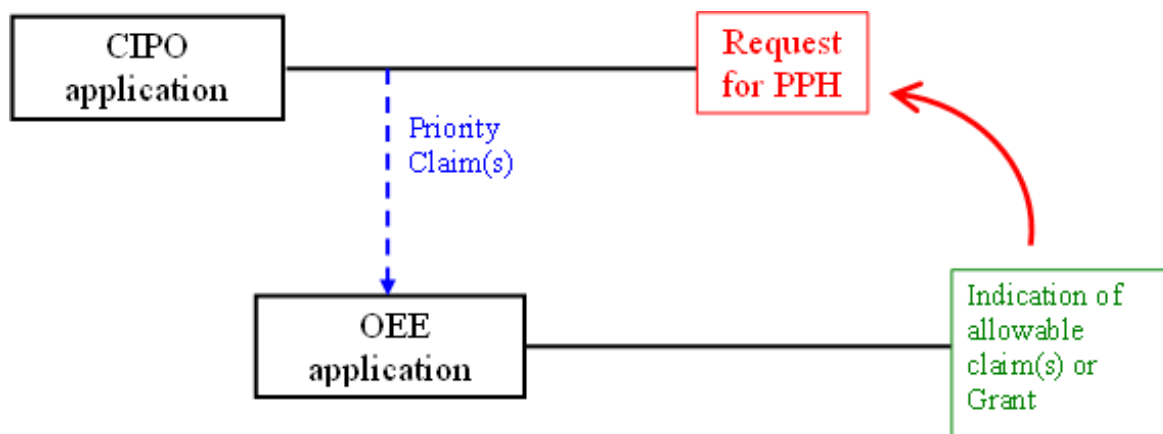

A nationally filed application at the OEE validly claims priority under the Paris Convention from a CIPO national application. The OEE national application has an indication of allowable subject matter or has granted as a patent. A PPH request is made for the nationally filed application at CIPO, based on the indication of allowable subject matter in the OEE or the OEE granted patent.

Example F

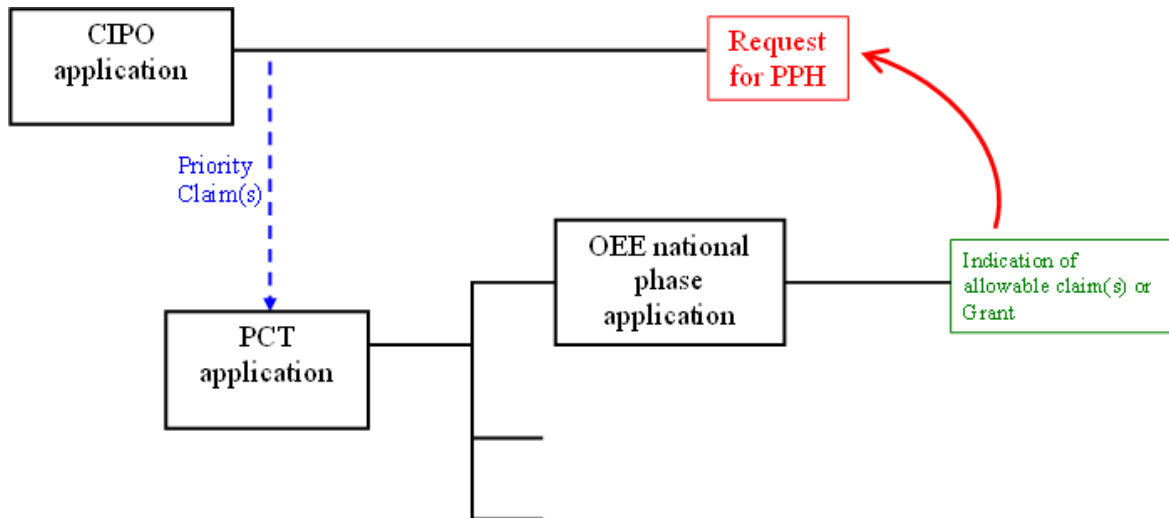

A PCT international application is filed and enters national phase at the OEE. The OEE national phase application has an indication of allowable subject matter or has granted as a patent. The PCT application validly claims priority from a CIPO national application. A PPH request is made for the national application at CIPO, based on the indication of allowable subject matter in the OEE or the OEE granted patent.

Example G

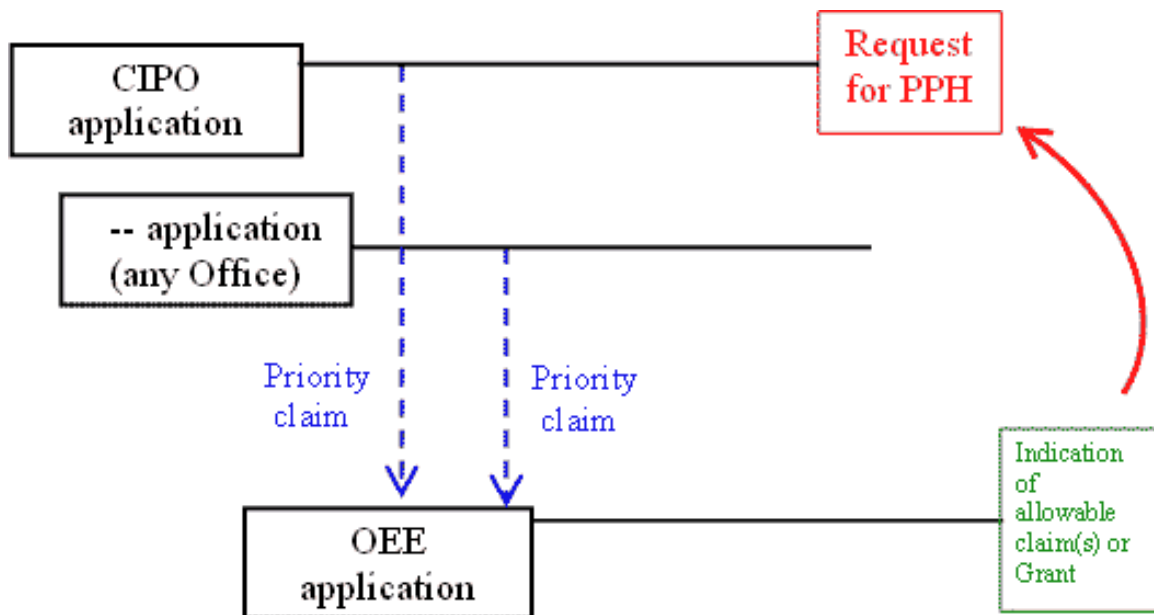

A nationally filed application at the OEE validly claims priority under the Paris Convention from two earlier applications: a CIPO national application and a national application filed at any office. The OEE national application has an indication of allowable subject matter or has granted as a patent. A PPH request is made for the nationally filed application at CIPO, based on the indication of allowable subject matter in the OEE or the OEE granted patent.

Example H

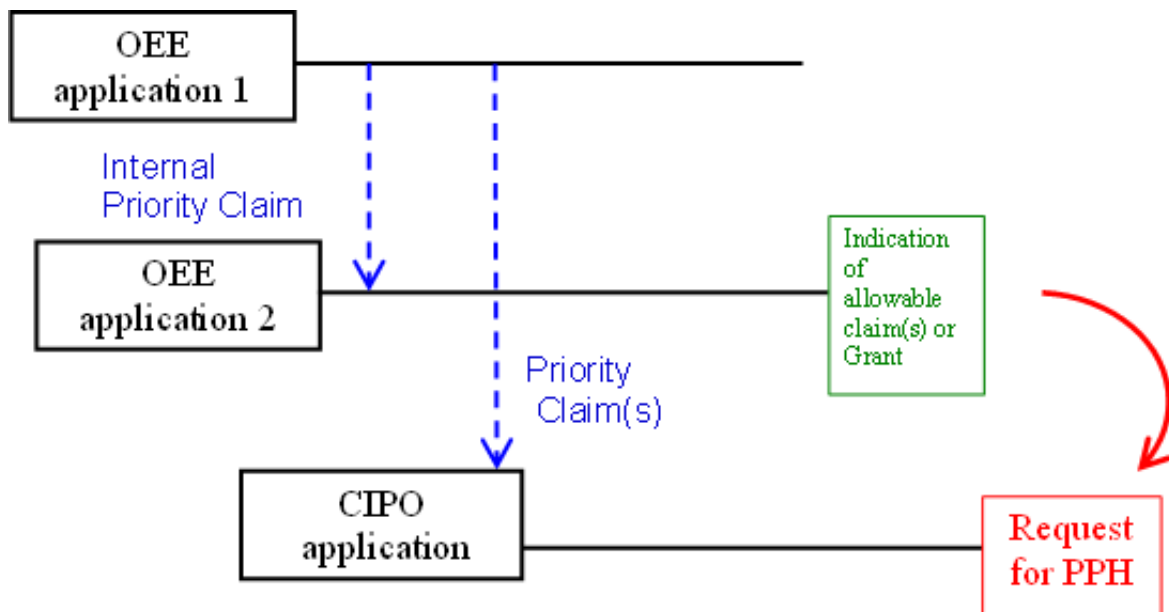

A nationally filed application at CIPO validly claims priority under the Paris Convention from OEE national application 1. OEE national application 2 validly claims internal priority from OEE national application 1 and has an indication of allowable subject matter or has granted as a patent. A PPH request is made for the nationally filed application at CIPO, based on the indication of allowable subject matter in the OEE or the OEE granted patent.

Example I

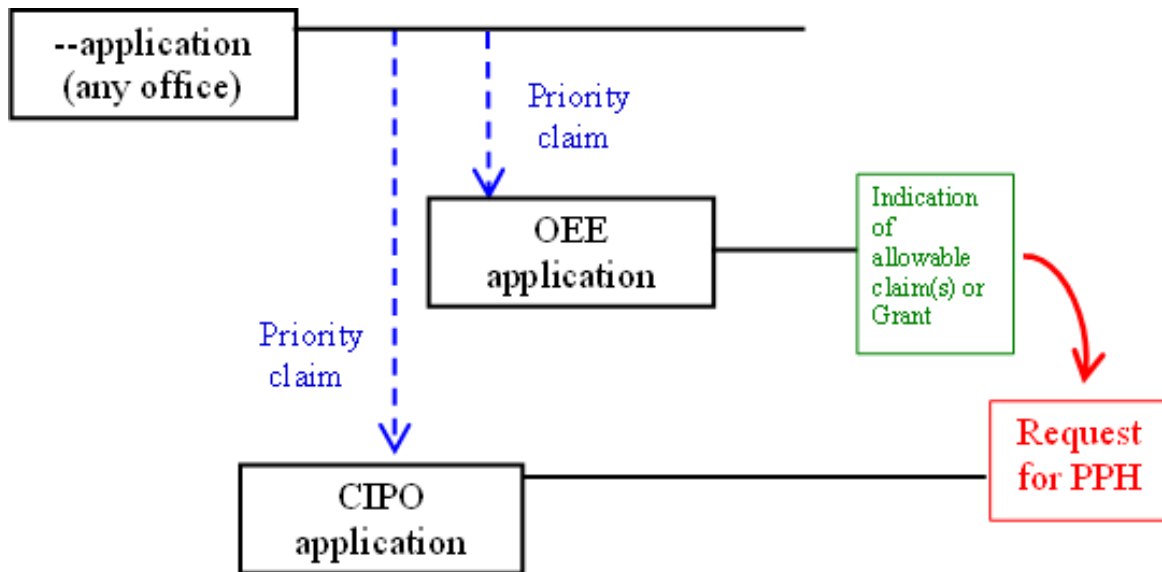

A nationally filed application at CIPO validly claims priority under the Paris Convention from an earlier national application filed at any office. An OEE national application claims priority to the same earlier application and has an indication of allowable subject matter or has granted as a patent. A PPH request is made for the nationally filed application at CIPO, based on the indication of allowable subject matter in the OEE or the OEE granted patent.

Example J

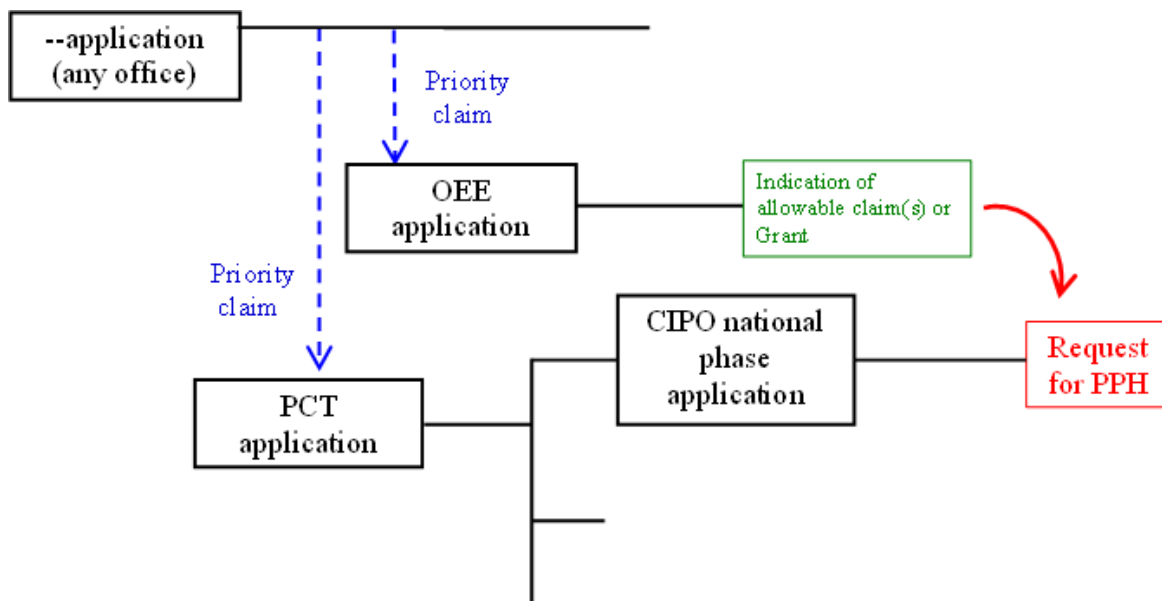

A PCT international application is filed and enters national phase at CIPO. The PCT application validly claims priority from a national application filed at any office. An OEE national application claims priority to the same earlier application and has an indication of allowable subject matter or has granted as a patent. A PPH request is made for the national phase application at CIPO, based on the indication of allowable subject matter in the OEE or the OEE granted patent.

Example K

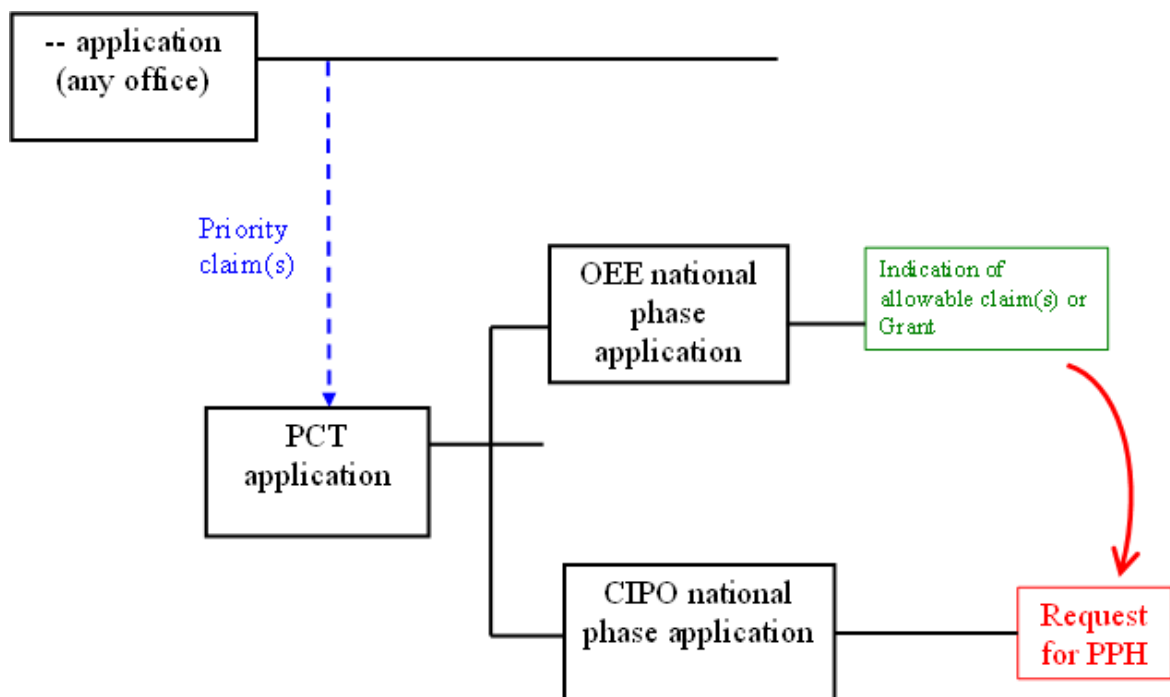

A PCT international application is filed and enters national phase at CIPO and the OEE. The PCT application validly claims priority from a national application filed at any office. The OEE national phase application receives an indication of allowable subject matter or is granted as a patent. A PPH request is made for the CIPO national phase application, based on the indication of allowable subject matter in the OEE or the OEE granted patent.

Example L

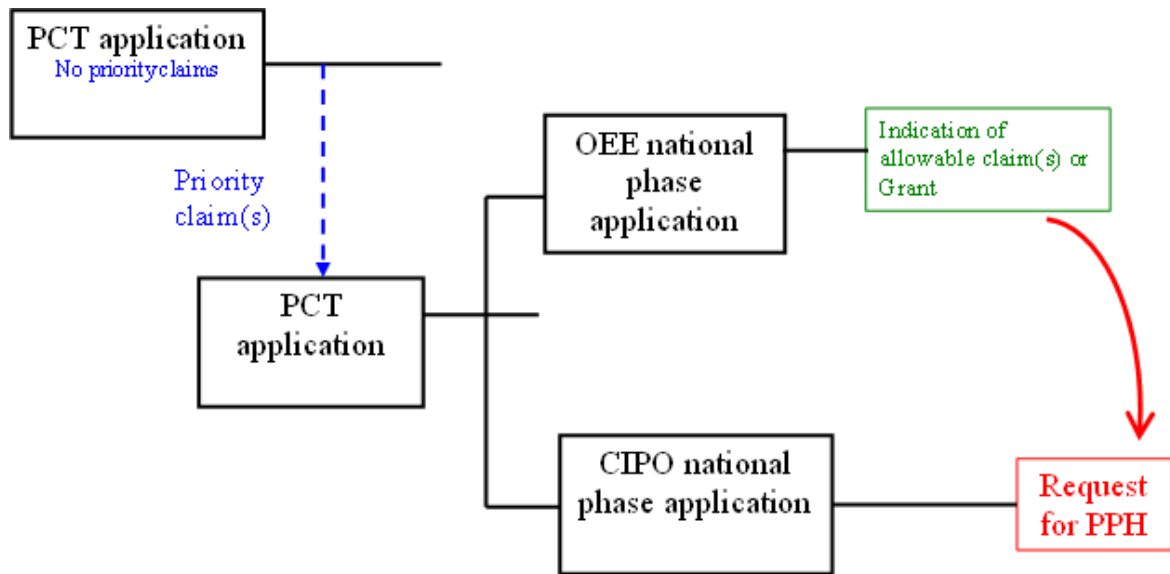

A PCT international application is filed and enters national phase at CIPO and the OEE. The national phase OEE application receives an indication of allowable subject matter or is granted as a patent. The PCT application validly claims priority from an earlier PCT application which has no priority claims. A PPH request is made for the national phase application at CIPO, based on the indication of allowable subject matter in the OEE or the OEE granted patent.

Example M

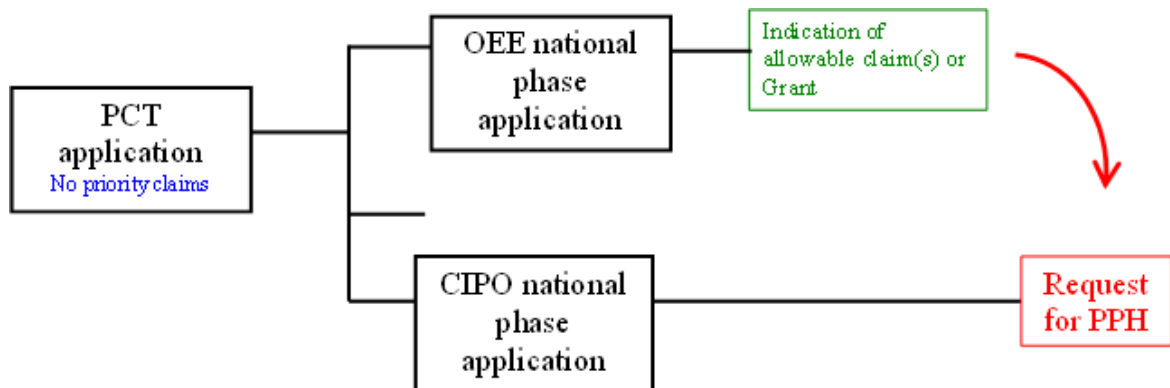

A PCT international application is filed and enters national phase at CIPO and the OEE. The PCT application has no priority claims. The OEE national phase application receives an indication of allowable subject matter or is granted as a patent. A PPH request is made for the CIPO national phase application, based on the indication of allowable subject matter in the OEE or the OEE granted patent.

Example N

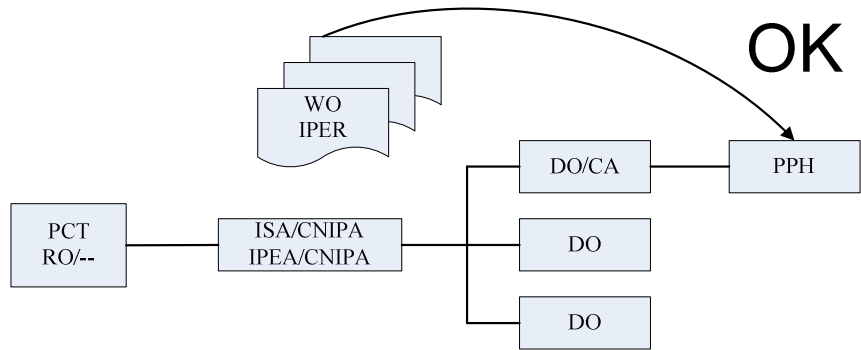

A PCT international application is filed and enters national phase at CIPO. CNIPA was the ISA or IPEA for the PCT application and provided an indication of allowable subject matter. A PPH request is made for the national phase application at CIPO, based on the indication of allowable subject matter in the PCT international application.

Example N'

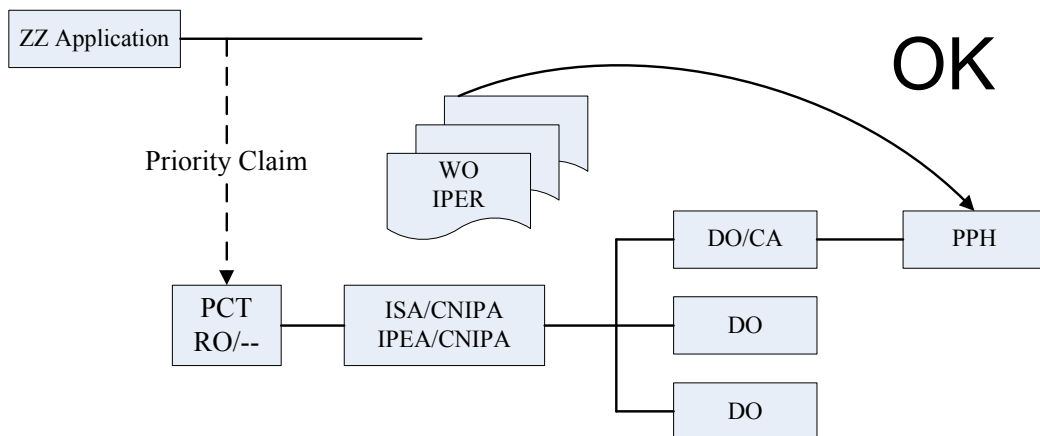

A PCT international application is filed and enters national phase at CIPO. The PCT application validly claims priority from a national application filed at any office. CNIPA was the ISA or IPEA for the PCT application and provided an indication of allowable subject matter. A PPH request is made for the national phase application at CIPO, based on the indication of allowable subject matter in the PCT international application.

Example N''

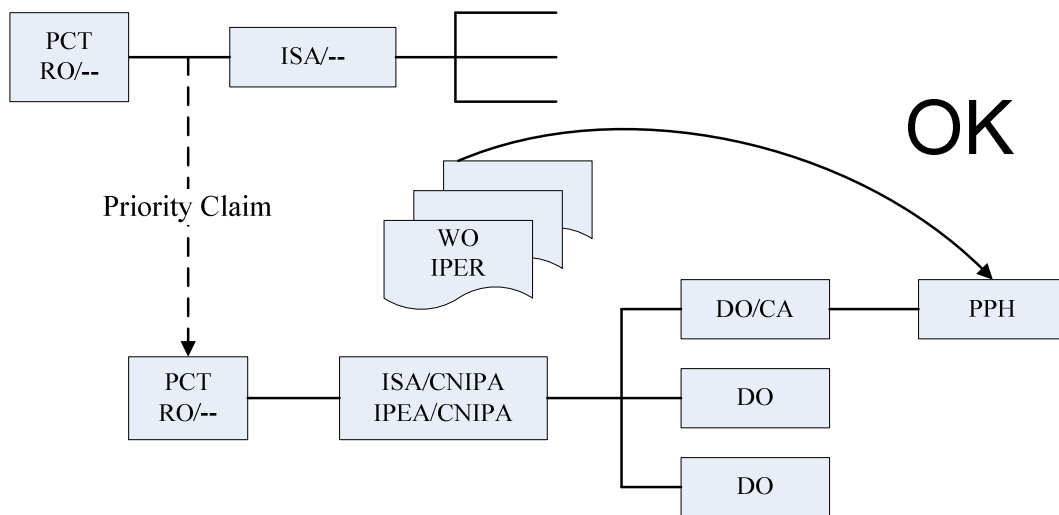

A PCT international application is filed and enters national phase at CIPO. The PCT application validly claims priority from a PCT international application filed at any office. CNIPA was the ISA or IPEA for the PCT application and provided an indication of allowable subject matter. A PPH request is made for the national phase application at CIPO, based on the indication of allowable subject matter in the PCT international application.

Example O

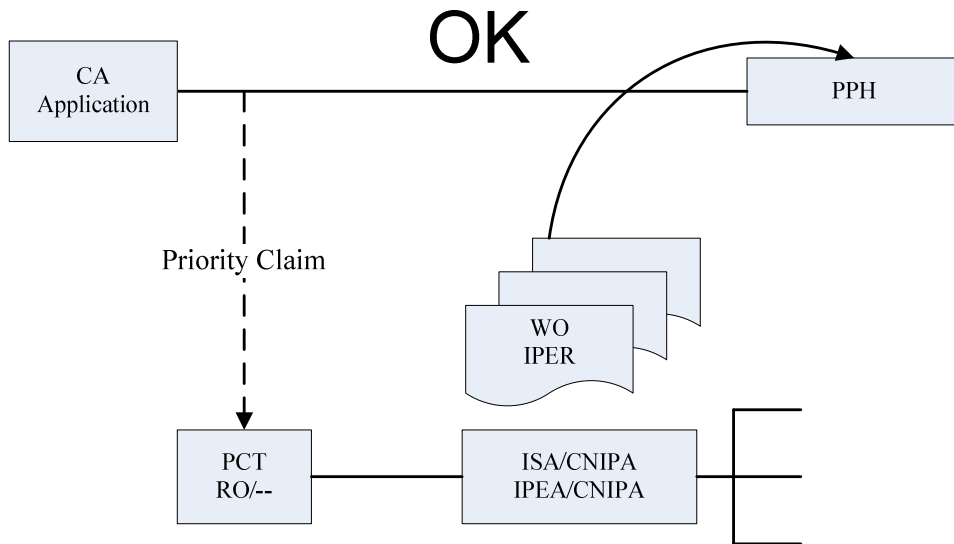

A PCT international application validly claims priority from a CIPO national application. CNIPA was the ISA or IPEA for the PCT application and provided an indication of allowable subject matter. A PPH request is made for the CIPO national application, based on the indication of allowable subject matter in the PCT international application.

Example P

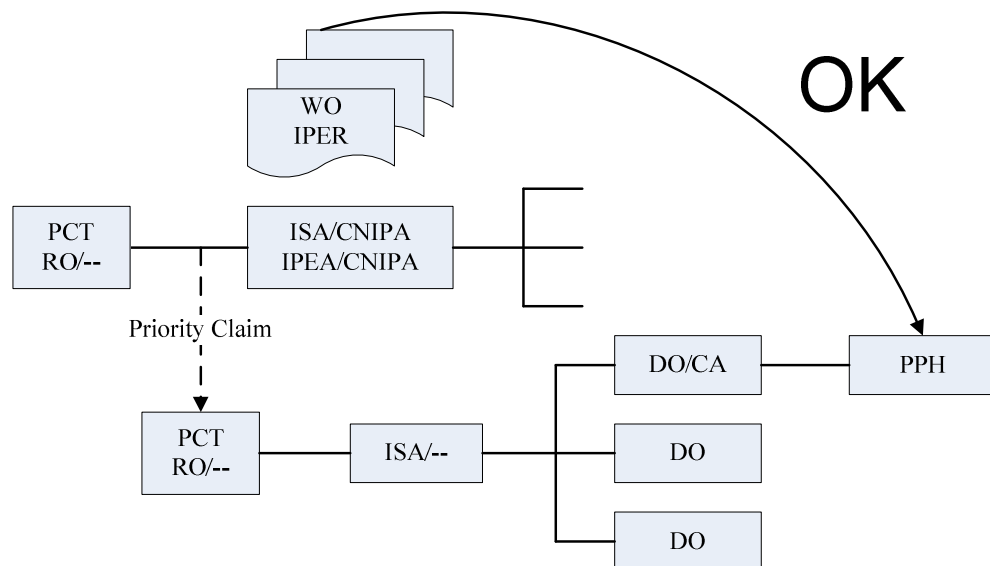

A PCT international application is filed at any office and enters national phase at CIPO. The PCT application validly claims priority from a previously filed PCT international application filed at any office. CNIPA was the ISA or IPEA for the previously filed PCT application filed at any office and provided an indication of allowable subject matter. A PPH request is made for the national phase application at CIPO, based on the indication of allowable subject matter in the PCT international application.

Example Q

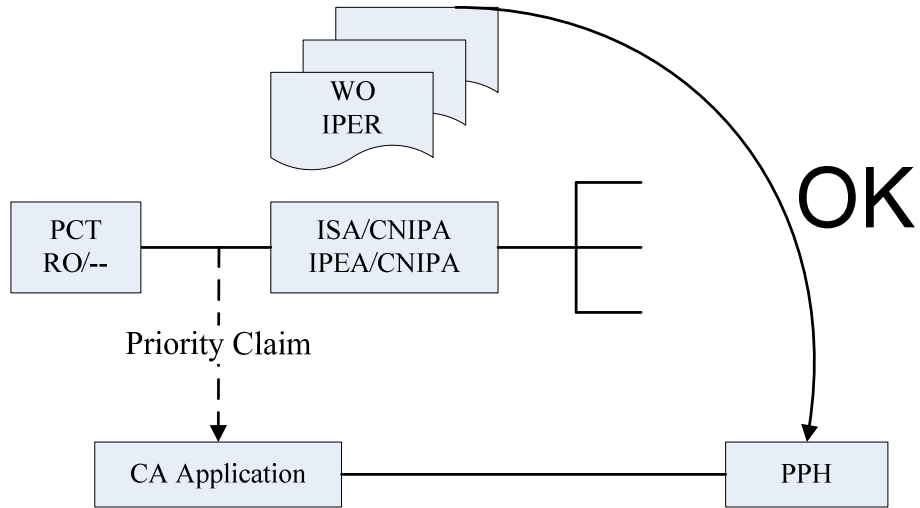

A nationally filed application at CIPO validly claims priority under the Paris Convention from a PCT international application filed at any office. CNIPA was the ISA or IPEA for the PCT application and provided an indication of allowable subject matter. A PPH request is made for the CIPO national application, based on the indication of allowable subject matter in the PCT international application.

Example R

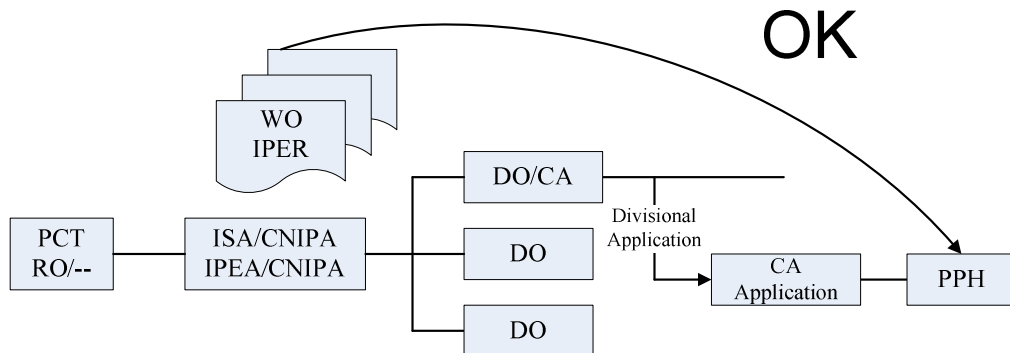

The application is a divisional application of an application which satisfies the scenario in Examples N, N' and N". A PPH request is made for the divisional application, based on the indication of allowable subject matter in the PCT international application.

Example S

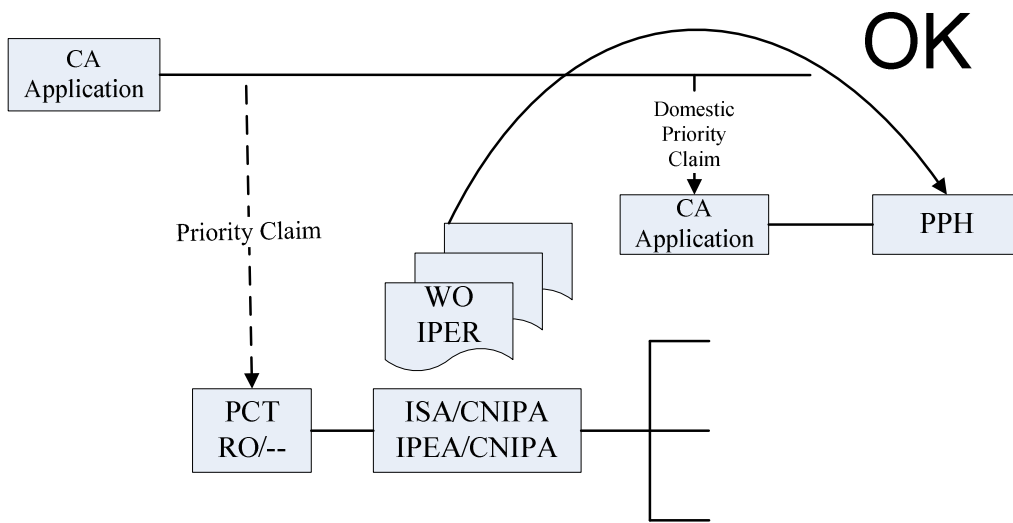

The application is an application claiming internal priority from an application which satisfies the scenario in Example O. A PPH request is made for the application claiming internal priority, based on the indication of allowable subject matter in the PCT international application.