

Procedures to File a Request to the NIPO (Norwegian Industrial Property Office) for Patent Prosecution Highway Pilot Program between the NIPO and the CNIPA (China National Intellectual Property Administration)

The pilot period of this PPH pilot program will commence on 1 April, 2020 for duration of three years and ending on 31 March, 2023. The pilot period may be extended if necessary until the CNIPA and NIPO receive sufficient number of PPH requests to adequately assess the feasibility of PPH program.

The Offices may also terminate the PPH pilot program if the volume of participation exceeds manageable level, or for any other reason. Ex Ante notice will be published if the PPH pilot program is terminated.

Part I

PPH using the national work products from the CNIPA

Applicants can request accelerated examination by a prescribed procedure including submission of relevant documents on an application which is filed with the NIPO and satisfies the following requirements under the CNIPA-NIPO Patent Prosecution Highway (PPH) pilot program based on the CNIPA application.

When filing a request for the PPH pilot program, an applicant must submit a request form “Request for Participation in the Patent Prosecution Highway (PPH) Pilot Program” [PPH request] to the NIPO.

1. Requirements

(1) The NIPO application (including PCT national phase application) is

- (i) an application which validly claims priority under the Paris Convention to the CNIPA application(s) (examples are provided in ANNEX I, Figures A, B, C, F, G and H), or***
- (ii) a PCT national phase application without priority claim (an example is provided in Annex I, Figures I), or***
- (iii) an application which validly claims priority under the Paris Convention to the PCT application(s) without priority claim (examples are provided in ANNEX I, Figures J, K and L).***

The NIPO application, which validly claims priority to multiple CNIPA or direct PCT

applications, or which is the divisional application validly based on the originally filed application that is included in (i) to (iii) above, is also eligible.

(2) *At least one corresponding application exists in the CNIPA which has one or more claims that are determined to be patentable/allowable by the CNIPA.*

The corresponding application(s) can be the application which forms the basis of the priority claim, an application which derived from the CNIPA application which forms the basis of the priority claim (e.g., a divisional application of the CNIPA application or an application which claims priority to the CNIPA application (see Figure C in Annex I)), or an

CNIPA national phase application of a PCT application (see Figures H, I, J, K and L in Annex I).

Claims are “determined to be allowable/patentable” when the CNIPA examiner explicitly identified the claims to be “allowable/patentable” in the latest office action, even if the application has not been granted yet.

Office actions mentioned above are:

- (i) Decision to Grant a Patent;
- (ii) First/Second/Third/...Office action;
- (iii) Decision of Refusal;
- (iv) Reexamination Decision;
- (v) Invalidation Decision.

(3) *All claims in the NIPO application (for which an accelerated examination under the PPH pilot program is requested), as originally filed or as amended, must sufficiently correspond to one or more of those claims determined to be patentable/allowable in the CNIPA.*

Claims are considered to “sufficiently correspond” where, aside from differences due to translations and claim format, the claims in the NIPO application are of the same or similar scope as the claims in the CNIPA application, or the claims in the NIPO are narrower in scope than the claims in the CNIPA.

In this regard, a claim that is narrower in scope occurs when CNIPA claim is amended to be further limited by an additional technical feature that is supported in the specification (description and/or claims).

A claim in the NIPO which introduces a new/different category of claims to those claims determined to be patentable/allowable in the CNIPA is not considered to sufficiently correspond. For example, if the CNIPA claims only contain claims to a process of manufacturing a product, then the claims in the NIPO are not considered to sufficiently correspond if the NIPO claims introduce product claims that are dependent on the corresponding process claims.

Any claims amended or added after the grant of the request for participation in the PPH pilot program need not to sufficiently correspond to the claims indicated as allowable in the CNIPA application.

- (4) *The NIPO has not begun examination of the application at the time of filing the PPH request.***

2. Documents to be submitted

Documents (1) to (4) below must be submitted by attaching to “Request for Participation in the Patent Prosecution Highway (PPH) Pilot Program”.

- (1) *Copies of all office actions (which are relevant to substantial examination for patentability in the CNIPA) which were issued for the corresponding application by the CNIPA, and translations thereof.***

Either Norwegian or English is acceptable as translation language. Machine translation will be admissible. If it is impossible for the examiner to understand the translated office action due to insufficient translation, the examiner can request the applicant to resubmit translations.

- (2) *Copies of all claims determined to be patentable/allowable by the CNIPA, and translations thereof.***

Either Norwegian or English is acceptable as translation language. If it is impossible for the examiner to understand the translated claims, the examiner can request the applicant to resubmit translations.

- (3) *Copies of references cited by the CNIPA examiner***

The documents to be submitted are those cited in the above-mentioned office actions.

If the references are patent documents, the applicant does not have to submit them. When the NIPO does not possess the patent document, the applicant has to submit the patent document at the examiner’s request. Non-patent literature must always be submitted. The translations of the references are unnecessary.

- (4) *Claim correspondence***

The applicant requesting PPH must indicate in section D of the “Request for Participation in the Patent Prosecution Highway (PPH) Pilot Program” how all claims in the NIPO application sufficiently correspond to the patentable/allowable claims in the CNIPA

application.

When claims are just literal translations of each other, the applicant can just enter “they are the same” in the table. When claims are not just literal translations, it is necessary to explain the sufficient correspondence of each claim based on the criteria 1.(3).

When the applicant has already submitted above documents (1) to (4) to the NIPO through simultaneous or past procedures, the applicant may incorporate the documents by reference and does not have to attach them.

3. Procedure for the accelerated examination under the PPH pilot program

The applicant files a request for accelerated examination under the PPH pilot program to the NIPO, including the relevant supporting documents and a completed request form (see sample form).

The NIPO decides whether the application can be entitled to the status for an accelerated examination under the PPH when it receives a request with the documents stated above. When the NIPO decides that the request is acceptable, the application is assigned a special status for an accelerated examination under the PPH.

In those instances where the request does not meet all the requirements set forth above, the applicant will be notified and the defects in the request will be identified. The applicant will be given opportunity to correct certain specified defects. If the defects are not corrected, the applicant will be notified and the application will await action in its regular turn.

Part II

PPH using the PCT international work products from the CNIPA

Applicants can request accelerated examination by a prescribed procedure including submission of relevant documents on an application which is filed with the NIPO and satisfies the following requirements under the NIPO-CNIPA Patent Prosecution Highway pilot program based on PCT international work products (PCT-PPH pilot program).

When filing a request for the PCT-PPH pilot program, an applicant must submit a request form “*Request for Participation in the Patent Prosecution Highway (PPH) Pilot Program*” [PPH request] to the NIPO.

1. Requirements

The application which is filed with the NIPO and on which the applicant files a request under the PCT-PPH must satisfy the following requirements:

- (1) The latest work product in the international phase of a PCT application corresponding to the application (“international work product”), namely the Written Opinion of International Search Authority (WO/ISA), the Written Opinion of International Preliminary Examination Authority (WO/IPEA) or the International Preliminary Examination Report (IPER), indicates at least one claim as patentable/allowable (from the aspect of novelty, inventive step and industrial applicability).**

Note that the ISA and the IPEA which produced the WO/ISA, WO/IPEA and the IPER are limited to the CNIPA, but, if priority is claimed, the priority claim can be to an application in any Office, see example A' in Annex II (application ZZ can be any national application).

The applicant cannot file a request under PCT-PPH on the basis of an International Search Report (ISR) only.

- (2) The relationship between the application and the corresponding international application satisfies one of the following requirements:**

- (A) The application is a national phase application of the corresponding international application. (See Figures A, A', and A'' in Annex II)**
- (B) The application is a national application as a basis of the priority claim of the corresponding international application. (See Figure B in Annex II)**
- (C) The application is a national phase application of an international application claiming priority from the corresponding international application. (See Figure C in Annex II)**

- (D) **The application is a national application claiming foreign/domestic priority from the corresponding international application. (See Figure D in Annex II)**
 - (E) **The application is the derivative application (divisional application and application claiming domestic priority etc.) of the application which satisfies one of the above requirements (A) – (D). (See Figures E1 and E2 in Annex II)**
- (3) All claims on file, as originally filed or as amended, for examination under the PCT-PPH must sufficiently correspond to one or more of those claims indicated to be patentable/allowable in the latest international work product of the corresponding international application.**

Claims are considered to "sufficiently correspond" where, accounting for differences due to translations and claim format, the claims of the application are of the same or similar scope as the claims indicated to be patentable/allowable in the latest international work product, or the claims of the application are narrower in scope than the claims indicated to be patentable/allowable in the latest international work product.

In this regard, a claim that is narrower in scope occurs when a claim indicated to be patentable/allowable in the latest international work product is amended to be further limited by an additional feature that is supported in the specification (description and/or claims) of the application.

A claim of the application which introduces a new/different category of claims to those claims indicated to be patentable/allowable in the latest international work product is not considered to sufficiently correspond. For example, if the claims indicated to be patentable/allowable in the latest international work product only contain claims to a process of manufacturing a product, then the claims of the application are not considered to sufficiently correspond if the claims of the application introduce product claims that are dependent on the corresponding process claims.

Any claims amended or added after the grant of the request for participation in the PCT-PPH pilot program need not to sufficiently correspond to the claims indicated as allowable in the latest international work product.

- (4) The NIPO has not begun examination of the application at the time of request for the PCT-PPH.**

2. Documents to be submitted

The applicant must submit the following documents attached to the request form in filing a request under PCT-PPH. Some of the documents may not be required to submit in certain cases.

(1) A copy of the latest international work product which indicated the claims to be patentable/allowable and their Norwegian or English translations.

If the copy of the latest international work product and the copy of the translation are available via “PATENTSCOPE (registered trademark)”¹, an applicant need not submit these documents, unless otherwise requested by the NIPO.

(WO/ISA and IPER are usually available as “IPRP Chapter I” and “IPRP Chapter II” respectively in 30 months after the priority date.)

If it is impossible for the examiner to understand the translated international work product, the examiner can request the applicant to resubmit translations.

(2) A copy of a set of claims which the latest international work product of the corresponding international application indicated to be patentable/allowable and their Norwegian or English translations.

If the copy of the set of claims which are indicated to be patentable/allowable is available via “PATENTSCOPE (registered trademark)”², an applicant need not submit this document unless otherwise requested by the NIPO.

If it is impossible for the examiner to understand the translated claims, the examiner can request the applicant to resubmit translations.

(3) A copy of references cited in the latest international work product of the international application corresponding to the application.

If the reference is a patent document, the applicant is not required to submit it. In case the NIPO has difficulty in obtaining the document, however, the applicant may be asked to submit it. Non-patent literature must always be submitted. Translations of cited references are unnecessary.

When an applicant has already submitted the above mentioned documents (1) - (3) to the NIPO through simultaneous or past procedures, the applicant may incorporate the documents by reference and is thus not required to attach the documents.

(4) Claim correspondence

The applicant requesting PCT-PPH must indicate in section D of the “Request for Participation in the Patent Prosecution Highway (PPH) Pilot Program” how all claims in the NIPO application sufficiently correspond to the patentable/allowable claims in the latest international work product.

¹<http://www.wipo.int/pctdb/en/index.jsp>

²<http://www.wipo.int/pctdb/en/index.jsp>

When claims are just literal translations of each other, the applicant can just enter “they are the same” in the table. When claims are not just literal translations, it is necessary to explain the sufficient correspondence of each claim based on the criteria 1.(3).

3. Procedure for the accelerated examination under the PCT-PPH pilot program

The applicant files a request for accelerated examination under the PCT-PPH pilot program to the NIPO, including the relevant supporting documents and a completed request form (see sample form).

The NIPO decides whether the application can be entitled to the status for an accelerated examination under the PCT-PPH when it receives a request with the documents stated above. When the NIPO decides that the request is acceptable, the application is assigned a special status for an accelerated examination under the PCT-PPH.

In those instances where the request does not meet all the requirements set forth above, the applicant will be notified and the defects in the request will be identified. The applicant will be given opportunity to correct certain specified defects.. If the resubmitted request is still not approved, the applicant will be notified and the application will await action in its regular turn.

Sample Form

https://www.patentstyret.no/globalassets/tjenester/skjema/engelsk/PPH_soknadsskjema.pdf

ANNEX I

A

A case meeting requirement (a) (i)
- Paris route -

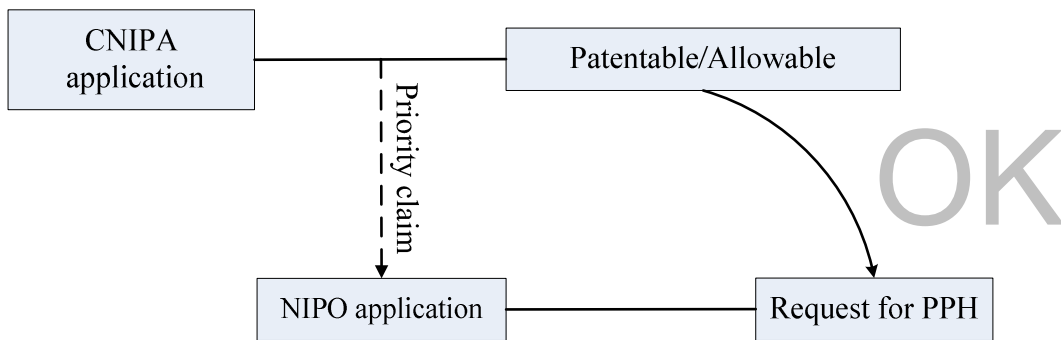

B

A case meeting requirement (a) (i)
- PCT route -

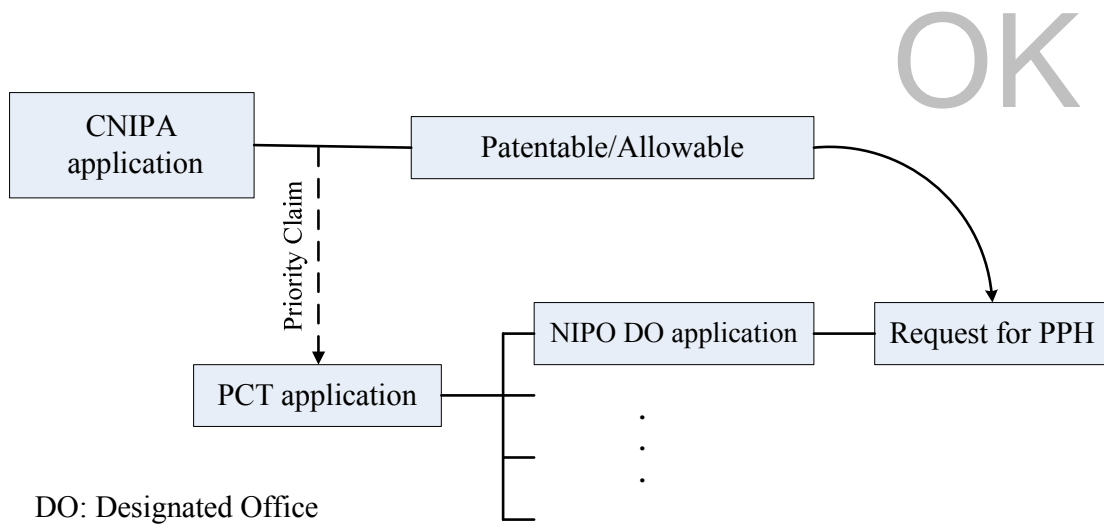

C

A case meeting requirement (a) (i)
- Paris route, Domestic priority -

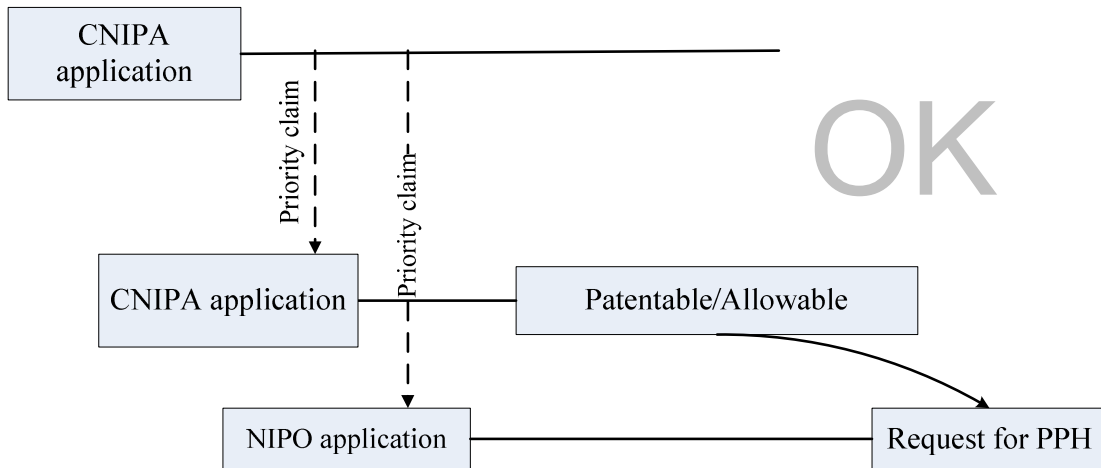

D

A case not meeting requirement (a)
- Paris route, but the first application is from the third office -

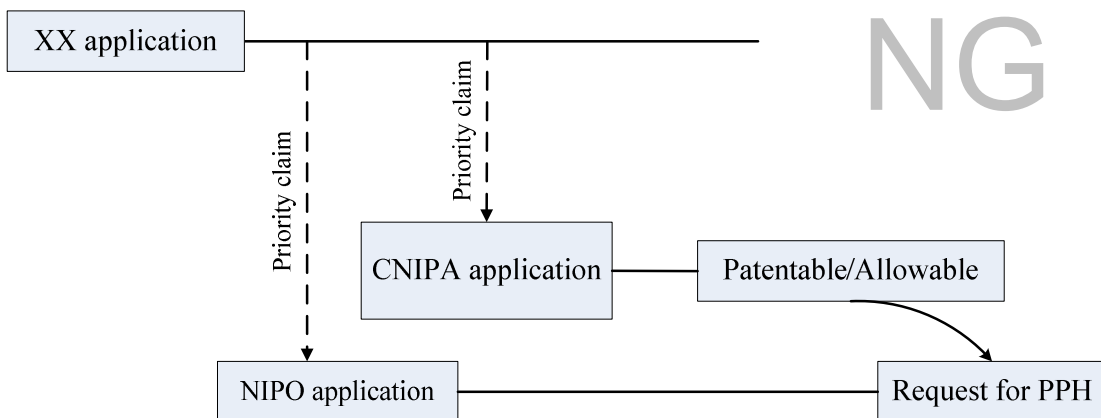

XX: the office other than the CNIPA

E

A case not meeting requirement (a)
- PCT route, but the first application is from the third office -

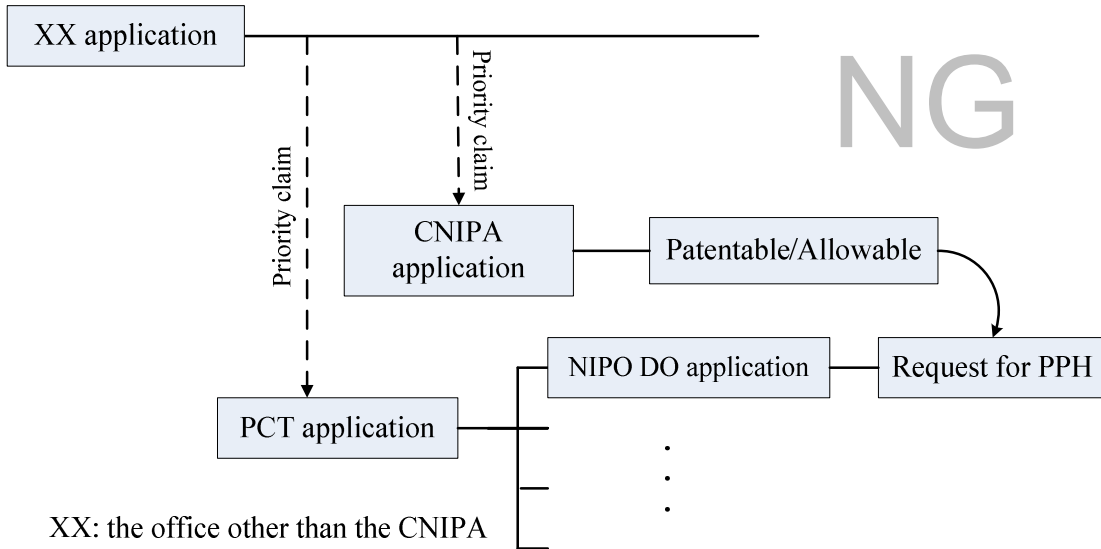

F

A case meeting requirement (a) (i)
- Paris route & complex priority -

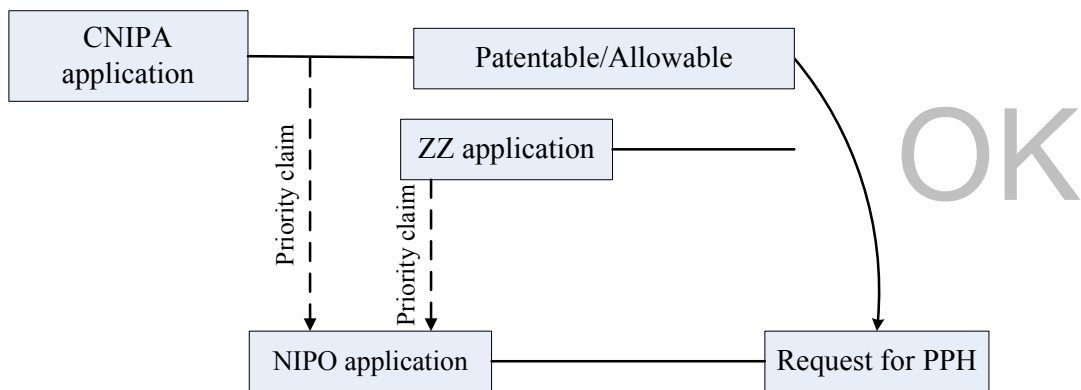

ZZ: any office

(The first application is from the CNIPA)

G

A case meeting requirement (a) (i)
- Paris route & divisional application -

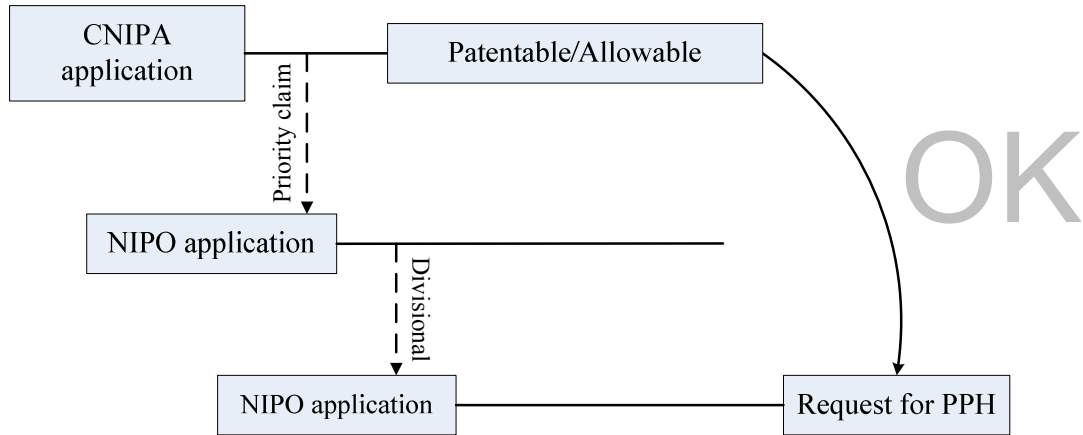

H

A case meeting requirement (a) (i)
- PCT route -

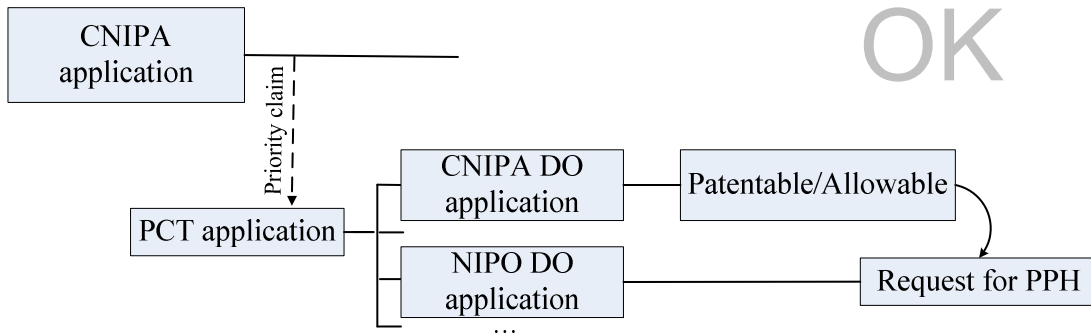

I

A case meeting requirement (a) (ii)
- Direct PCT route -

OK

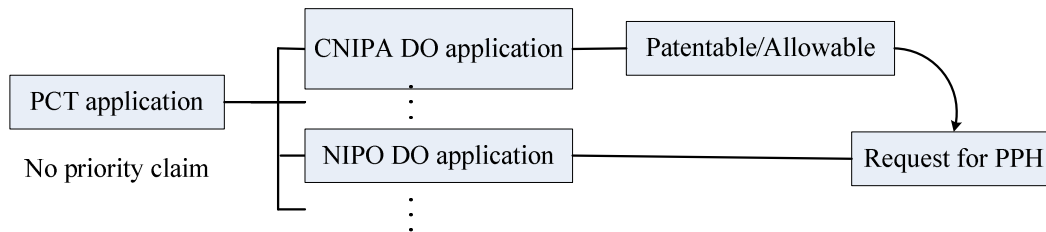

J

A case meeting requirement (a) (iii)
- Direct PCT & Paris route -

OK

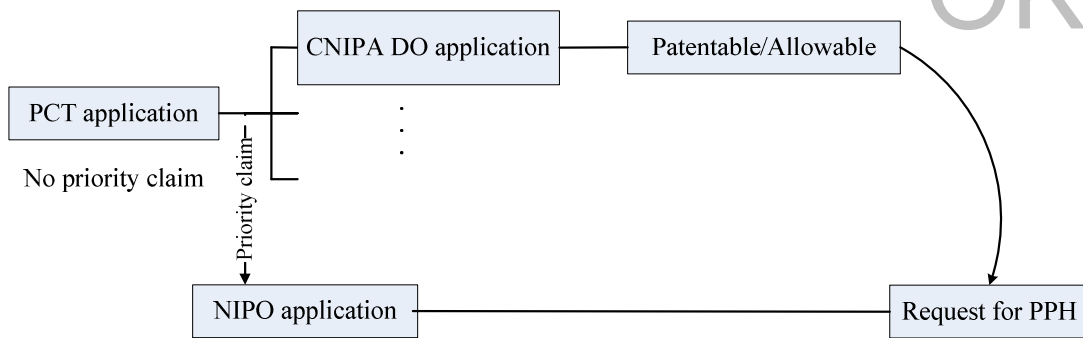

K

A case meeting requirement (a) (iii)
- Direct PCT & PCT route -

OK

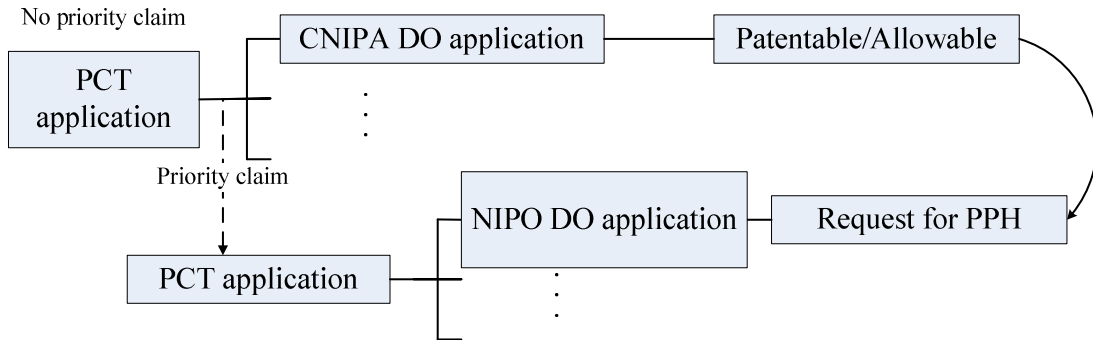

L

A case meeting requirement (a) (iii)
- Direct PCT & PCT route -

OK

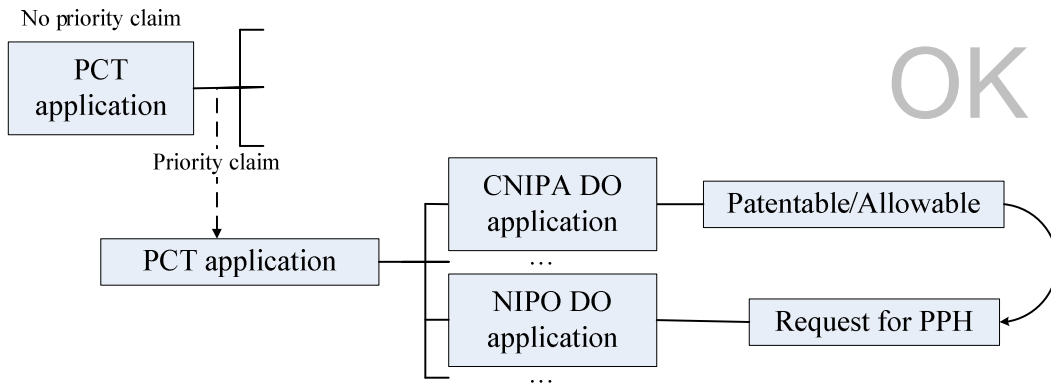

M

A case not meeting requirement (f)
- Examination has begun before a request for PPH -

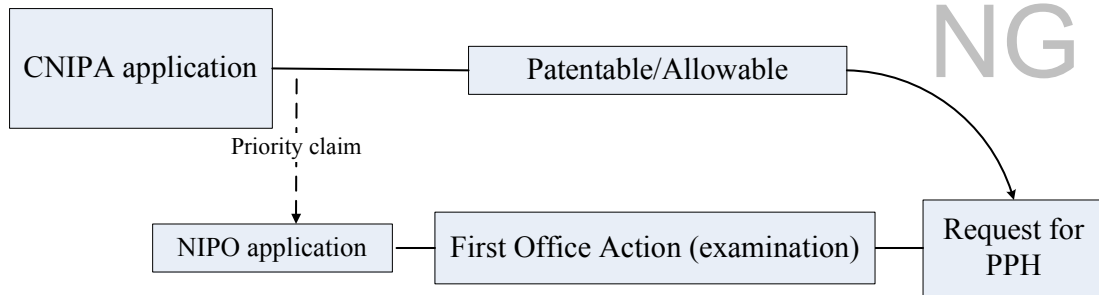

ANNEX II

(A) The application is a national phase application of the corresponding international application.

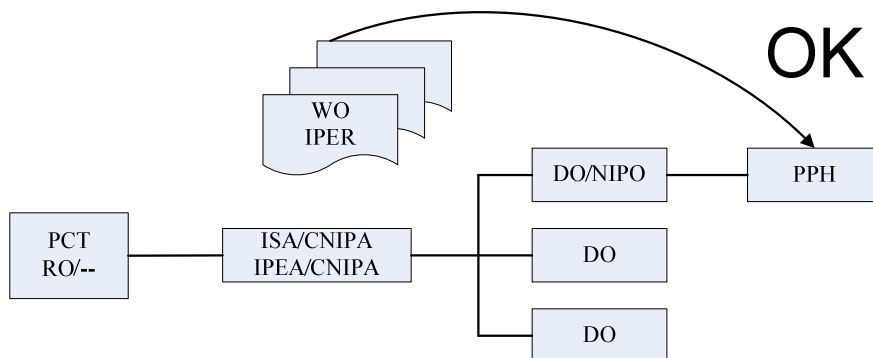

(A*) The application is a national phase application of the corresponding international application. (The corresponding international application claims priority from a national application.)

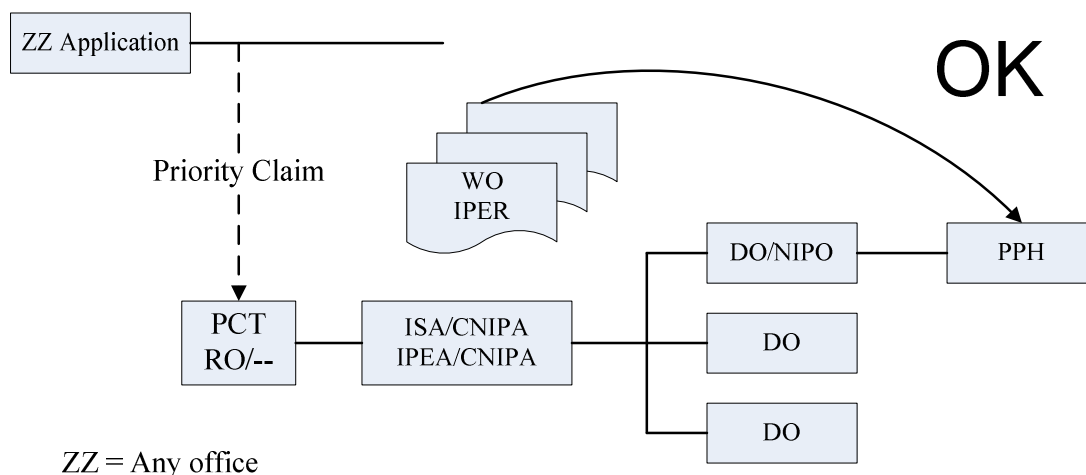

**(A'') The application is a national phase application of the corresponding international application.
(The corresponding international application claims priority from an international application.)**

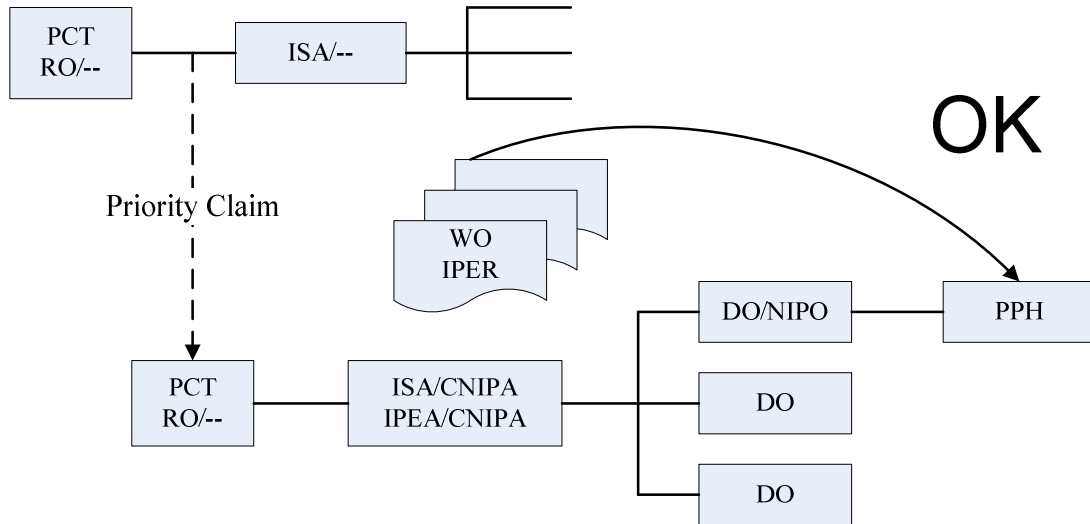

(B) The application is a national application as a basis of the priority claim of the corresponding international application.

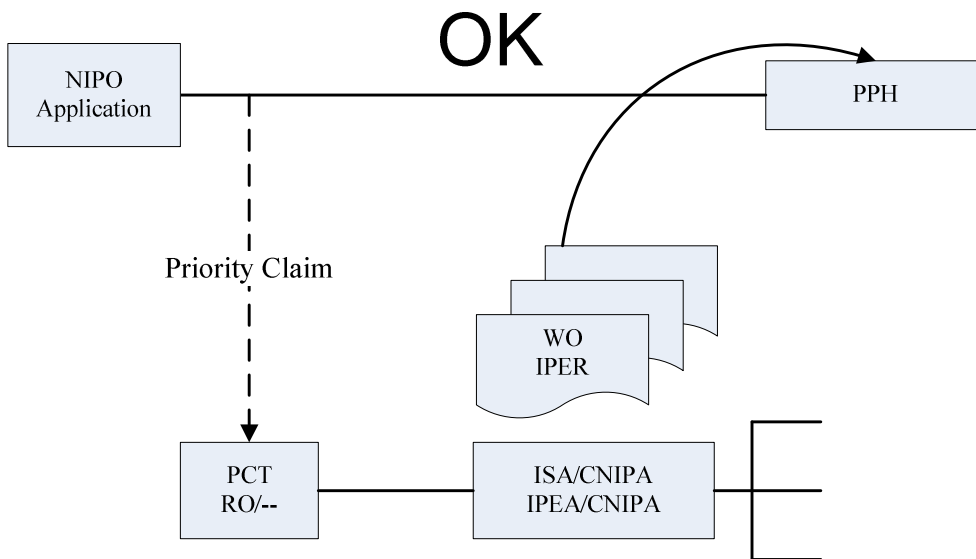

(C) The application is a national phase application of an international application claiming priority from the corresponding international application.

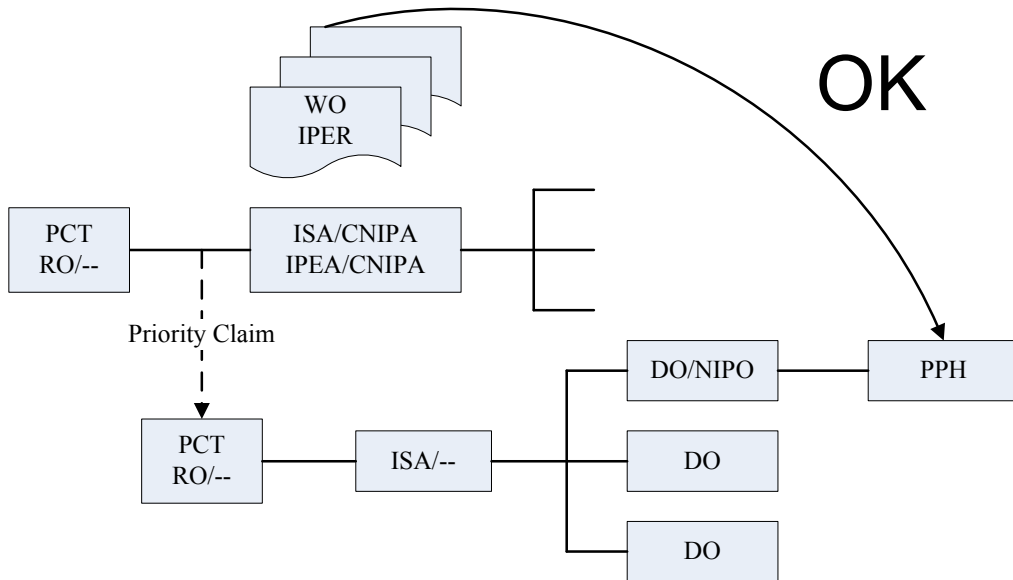

(D) The application is a national application claiming foreign/domestic priority from the corresponding international application.

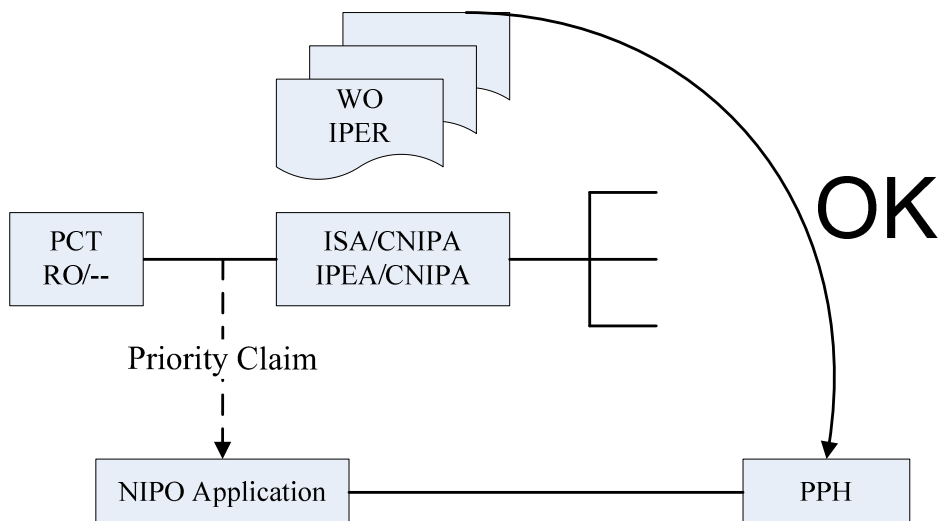

(E1) The application is a divisional application of an application which satisfies the requirement (A).

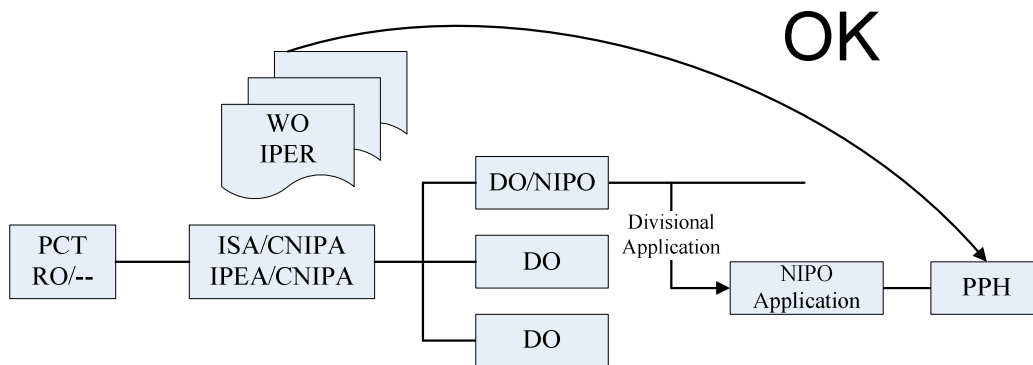

(E2) The application is an application claiming domestic priority from an application which satisfies the requirement (B).

